



**Australian  
Building  
Codes Board**

# **Livable Housing Design Standard**



**2022**

## Copyright and Licence Notice

© Commonwealth of Australia and the States and Territories of Australia 2022, published by the Australian Building Codes Board

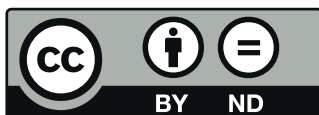

The material in this publication is licensed under a Creative Commons Attribution-NoDerivatives - 4.0 International licence, with the exception of:

- any third party material
- any trade marks, and
- any images or photographs.

You may not make derivatives of this publication, but may only use a verbatim copy. More information on this CC BY ND license is set out at the Creative Commons Website. Enquiries about this publication can be sent to:

Australian Building Codes Board

GPO Box 2013, Canberra ACT 2601

Phone: 1300 134 631

Email: [ncc@abcb.gov.au](mailto:ncc@abcb.gov.au)

Web: [abcb.gov.au](http://abcb.gov.au)

### Attribution

Use of all or part of this publication must include the following attribution: © Commonwealth of Australia and the States and Territories 2022, published by the Australian Building Codes Board.

### Disclaimer

By accessing or using this publication, you agree to the following:

While care has been taken in the preparation of this publication, it may not be complete or up-to-date. You can ensure that you are using a complete and up-to-date version by checking the Australian Building Codes Board website ([abcb.gov.au](http://abcb.gov.au)).

The Australian Building Codes Board, the Commonwealth of Australia and States and Territories of Australia do not accept any liability, including liability for negligence, for any loss (howsoever caused), damage, injury, expense or cost incurred by any person as a result of accessing, using or relying upon this publication, to the maximum extent permitted by law. No representation or warranty is made or given as to the currency, accuracy, reliability, merchantability, fitness for any purpose or completeness of this publication or any information which may appear on any linked websites, or in other linked information sources, and all such representations and warranties are excluded to the extent permitted by law.

This publication is not legal or professional advice. Persons rely upon this publication entirely at their own risk and must take responsibility for assessing the relevance and accuracy of the information in relation to their particular circumstances.

## General table of contents

### Front matter

Copyright and Licence Notice.....	2
Introduction .....	4
Referenced documents .....	5

### Livable Housing Design

Part 1	Dwelling access .....	7
Part 2	Dwelling entrance.....	9
Part 3	Internal doors and corridors .....	12
Part 4	Sanitary compartment.....	13
Part 5	Shower.....	15
Part 6	Reinforcement of bathroom and sanitary compartment walls .....	16

# Introduction

## Background

This ABCB Standard provides a set of technical provisions that if complied with will enable dwellings to better meet the needs of the community, including older people and people with mobility limitations.

This ABCB Standard has been adapted from the 'Silver' level requirements of the Livable Housing Design Guidelines (LHDG), fourth edition, 2017, which were first published by Livable Housing Australia.

It is important to note that this ABCB Standard is not an exact replication of the LHDG. There are instances where adjustments have been made in order to convert the LHDG — which was drafted as a voluntary guideline — into a document suitable for use as a regulatory standard. There are also instances where adjustments have been made in response to stakeholder feedback provided through one or more of the consultation processes that occurred in the development of this document.

## Scope

This ABCB Standard is intended as a set of minimum necessary provisions, rather than as an exemplar of best practice. This is consistent with the role of the National Construction Code (NCC) which calls up this ABCB Standard.

This ABCB Standard is not intended for use in designing specialist accommodation, nor is it intended to achieve equivalence with AS 1428.1. Therefore, its provisions may not accommodate the needs and abilities of all home occupants. Nonetheless, the features described herein are considered to be of most widespread benefit and use in the majority of circumstances.

## Application

In this ABCB Standard, generic references are made to 'dwellings'. The specific application of this ABCB Standard to particular types of dwelling is determined according to the particular regulation or guideline in which the ABCB Standard may be referenced.

In general, the provisions of this ABCB Standard are designed for application to Class 1a buildings (houses and the like) and Class 2 *sole-occupancy units* (apartments), as defined in the NCC.

This ABCB Standard is referenced in the *Deemed-to-Satisfy Provisions* of Part G7 of NCC Volume One and Part H8 of NCC Volume Two.

This ABCB Standard is not intended to be read in isolation and must only be used in conjunction with the relevant Part of the NCC.

The ABCB will also publish a non-mandatory version of this ABCB Standard based on the LHDG 'Gold' level requirements, which can be applied on a voluntary basis to achieve a higher level of livability.

## Terms with a specific meaning

In this ABCB Standard, terms shown in italicised text have the meaning that they have in the NCC.

## Referenced documents

The documents listed in Table 1 are referenced in this Standard.

**Table 1: Referenced documents**

Number	Date	Title	References
AS/NZS 1170.1	2002	Structural design actions – Permanent and imposed actions (including Amendments 1 and 2)	1.1
AS 1684 Part 2	2021	Residential timber-framed construction — Non-cyclonic areas	1.1
AS 1684 Part 3	2021	Residential timber framed construction — Cyclonic areas	1.1
AS 1684 Part 4	2010	Residential timber framed construction — Simplified — Noncyclonic areas (incorporating amendment 1)	1.1
AS 3600.1	2014	Termite management — New building work (incorporating amendment 1)	2.4
AS 3959	2018	Construction of buildings in bushfire-prone areas (incorporating amendments 1 and 2)	2.4
NASH Standard Parts 1 and 2	Part 1: 2005 (incorporating Amendments A, B and C); Part 2: 2014 (incorporating Amendment A)	Residential and Low-rise Steel Framing	1.1

# Livable Housing Design

<b>Part 1</b>	<b>Dwelling access</b>
1.1	Step-free access path
1.2	Parking space incorporated into step-free access path
<b>Part 2</b>	<b>Dwelling entrance</b>
2.1	Clear opening width
2.2	Threshold
2.3	Landing area
2.4	Weatherproofing for external step-free entrance
<b>Part 3</b>	<b>Internal doors and corridors</b>
3.1	Clear opening width
3.2	Threshold
3.3	Corridor width
<b>Part 4</b>	<b>Sanitary compartment</b>
4.1	Location
4.2	Circulation space
<b>Part 5</b>	<b>Shower</b>
5.1	Application
5.2	Hobless and step-free entry
<b>Part 6</b>	<b>Reinforcement of bathroom and sanitary compartment walls</b>
6.1	Location
6.2	Construction

## Part 1 Dwelling access

### 1.1 Step-free access path

- (1) A continuous path to a dwelling entrance door must be provided from—
  - (a) the pedestrian entry at the allotment boundary from the ground level of the adjoining land; or
  - (b) an appurtenant Class 10a garage or carport; or
  - (c) a car parking space within the allotment that is provided for the exclusive use of the occupants of the dwelling.
- (2) Access for the purposes of (1) must be—
  - (a) via a pathway that—
    - (i) has no steps; and
    - (ii) except for a step ramp provided under (5), has a maximum gradient of 1:14 in the direction of travel; and
    - (iii) if crossfall is provided, has a crossfall not more than 1:40; and
    - (iv) has a minimum width of 1000 mm; and
    - (v) if it incorporates a section suspended above finished ground level, is able to take loading forces in accordance with AS/NZS 1170.1; and
    - (vi) connects to a dwelling entrance door that complies with Section 2; or
  - (b) provided directly from an attached Class 10a garage or carport, via a door complying with the requirements of Section 2, other than [Clause 2.3](#).
- (3) For the purposes of (2), the following applies:
  - (a) Any gates along the access path must have a minimum clear opening width of 820 mm, measured as if the gate were an entrance door.
  - (b) A deck or boardwalk-style path constructed in accordance with AS 1684 or NASH Standard – Residential and Low-rise Steel Framing would satisfy the requirements of (2)(a)(v).
- (4) Where one or more ramps are used, the following applies:
  - (a) The aggregate length of ramping (excluding landings) must not be more than—
    - (i) 9 m for a 1:14 gradient; or
    - (ii) 15 m for a 1:20 gradient; or
    - (iii) a length determined by linear interpolation for ramps with a gradient between 1:14 and 1:20.
  - (b) The minimum width of the ramp must be maintained at 1000 mm between any handrails and/or kerbs (if provided) at each side of the ramp.
  - (c) At each end of a ramp there must be a landing that is—
    - (i) not less than 1200 mm long; and
    - (ii) at least as wide as the ramp to which it connects; and
    - (iii) level, or has a gradient not more than 1:40 if a gradient is necessary for drainage.
  - (d) A landing area required by [Clause 2.3](#) may also be counted as a landing for the purposes of (c).
- (5) The access path may incorporate one step ramp having a—
  - (a) height of not more than 190 mm; and
  - (b) gradient not more than 1:10; and
  - (c) width of at least 1000 mm or equivalent to that of the access path, whichever is the greater; and
  - (d) maximum length of 1900 mm.

#### Applications

Clause 1.1 only applies to a Class 1a building.

**Information: Access via a garage, carport or parking space**

Where step-free access is provided from a garage, carport or parking space, this can be through a connecting door between the garage, carport or parking space and the dwelling. The connecting door need not be the main entrance door (sometimes referred to as the 'front' door) but would need to comply with Section 2. Any carparking spaces forming part of the required path of travel must be free of obstructions, including structural elements such as columns or engaged brick piers that would otherwise reduce the space for free movement.

**Information: Class 2 buildings**

For a Class 2 building, requirements for a step-free access path are provided in Section D of NCC Volume One and the 'Disability (Access to Premises — Buildings) Standards 2010'. Therefore, Clause 1.1 only applies to Class 1a buildings.

## 1.2 Parking space incorporated into step-free access path

- (1) Where one or more car parking spaces are connected to or form part of a required access path, at least one of the car parking spaces must have—
  - (a) a minimum unobstructed car parking space of 3200 mm wide x 5400 mm long; and
  - (b) a gradient not more than 1:33 for bitumen, or 1:40 for any other surface material.
- (2) For the purposes of (1), a required access path means an access path provided for the purposes of compliance with Clause 1.1.

**Applications**

- (1) Clause 1.2 only applies to a car parking space provided for the exclusive use of the occupants of the dwelling.
- (2) Clause 1.2 does not apply—
  - (a) if there are no car parking spaces provided for the exclusive use of the occupants of the dwelling; or
  - (b) to a Class 2 building.



## Part 2 Dwelling entrance

### 2.1 Clear opening width

- (1) At least one entrance door to the dwelling must have a minimum clear opening width of 820 mm.
- (2) The minimum clear opening width required by (1) must be measured in accordance with Figure 2.1.

Figure 2.1: Measurement of clear opening width

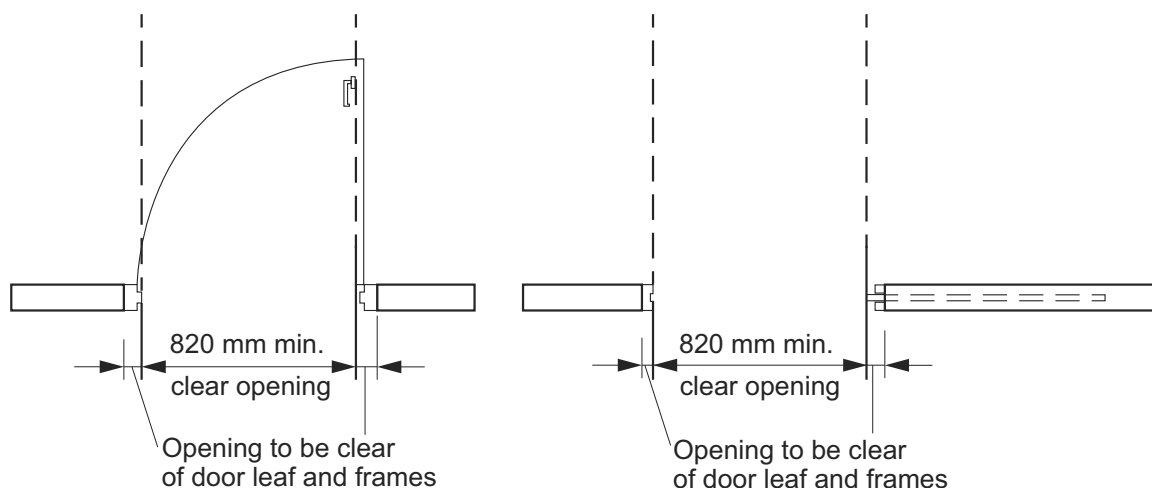

#### Figure Notes

- (1) Double doors, bi-fold doors, stacking doors, multiple sliding door panels and other types of hinged door sets may use a smaller leaf provided the overall clear opening width with the doors fully open is not less than 820 mm.
- (2) Clear opening width for sliding doors must be measured with the door panel(s) installed and in the fully open position.
- (3) The door handle may encroach the required minimum clear opening width.

#### Information: Door leaf dimensions

An 820 mm clear opening width, for a single swinging door, can generally be achieved using an 870 mm door leaf.

#### Information: Meaning of 'entrance door'

An entrance door for the purposes of 2.1 may be a door other than the front door, provided that the door connects to the step-free access path in accordance with Clause 1.1(2). For example, compliance with 2.1 could be achieved via a side door that is connected to the garage via a step-free path.

### 2.2 Threshold

The threshold of an entrance door that is subject to Clause 2.1 must—

- (a) be level; or
- (b) have a sill height not more than 5 mm if the lip is rounded or bevelled; or
- (c) have a ramped threshold that—
  - (i) does not extend beyond the depth of the door jamb; and
  - (ii) has a gradient not steeper than 1:8; and
  - (iii) is at least as wide as the minimum clear opening width of the entrance door; and
  - (iv) does not intrude into the minimum dimensions of a landing area that is required by Clause 2.3; or

- (d) for external entrance doors, have a sill with a total lip height not more than 15 mm and with no one part of the profile or upstand greater than 5 mm in any part of its profile.

#### Information: Termite management

For termite management, where *required* by the NCC, the NCC referenced document AS 3660.1 includes solutions for termite management in cases where there is no step-up into a dwelling: see clauses 2.2, 2.3, 4.4 and 6.5 of AS 3660.1. AS 3660.1 is referenced in the NCC, therefore an appropriate solution for termite management that complies with AS 3660.1 can be used as part of a *Deemed-to-Satisfy Solution* under the NCC.

#### Information: Damp-proof course

For masonry construction, a *damp-proof course* is to be located above the external finished surface (e.g. clause 5.7.4 of the ABCB Housing Provisions). Therefore, the construction of a ramp, threshold or the like is to maintain compliance with this requirement.

## 2.3 Landing area

An entrance door that is subject to [Clause 2.1](#) must have a space of at least 1200 mm x 1200 mm on the external (arrival) side of the door that is—

- (a) unobstructed (other than by a gate or a screen door); and
- (b) level, or has a gradient not more than 1:40 if a gradient is necessary to allow for drainage.

#### Applications

- (1) Clause 2.3 only applies to a Class 1a building.
- (2) Clause 2.3 does not apply to a dwelling that is exempt from compliance with [Clause 1.1](#).
- (3) Clause 2.3 does not apply to an entrance door that serves an appurtenant Class 10a garage or carport in accordance with 1.1(b).

#### Information: Entrance doors to Class 2 sole-occupancy units

Requirements for landing areas outside the entrance door to a Class 2 *sole-occupancy unit* located on an *accessible* floor are set out in Section D of NCC Volume One and the Disability (Access to Premises — Buildings) Standards 2010.

## 2.4 Weatherproofing for external step-free entrance

Weatherproofing for an external step-free entrance must be provided in accordance with one or a combination of the following:

- (a) Where the external surface is concrete or another impermeable surface, a channel drain that meets the requirements of Volume Two [H2D2](#) is to be provided for the width of the entrance.
- (b) Where the external trafficable surface is decking or another raised permeable surface, a drainage surface below the trafficable surface is to be provided that meets the requirements of Volume Two [H2D2](#), and drainage gaps in the trafficable surface, such as those between decking boards, are to be no greater than—
  - (i) 8 mm; or
  - (ii) in a *designated bushfire prone area*, that permitted by AS 3959.
- (c) A roof covering an area no smaller than 1200 mm by 1200 mm, where the area is provided with a fall away from the building not greater than 1:40.

#### Applications

- (1) The provisions of 2.4 do not apply to an entrance door that is provided through an interconnected garage.
- (2) A channel drain provided in accordance with (a) can also act as an inspection zone for the purposes of termite management provisions provided the inspected zone required by AS 3660.1 can be accessed.

## Livable Housing Design

---

- (3) Consideration should be given to the ability for cleaning drains in (a), particularly in bushfire prone areas.
- (4) For the purposes of (c), any posts, columns, or structural supports for the roof cover, must not encroach the clear space required by 1.1(4) for a landing or entrance path provided under 1.1.

## Part 3 Internal doors and corridors

### 3.1 Clear opening width

Internal doorways must provide a minimum clear opening width of 820 mm, measured in accordance with [Figure 2.1](#).

#### Applications

Clause 3.1 only applies to a doorway that connects to, or is in the path of travel to, any of the following:

- (a) *Habitable room* or laundry on the ground or entry level.
- (b) Attached Class 10a garage or carport that forms part of an access path required by [Clause 1.1](#).
- (c) *Sanitary compartment* on the ground or entry level complying with [Parts 4](#) and [6](#).
- (d) room containing a shower complying with [Parts 5](#) and [6](#).

#### Information: Clear opening width

An 820 mm clear opening width, for a single swinging door, can generally be achieved using an 870 mm door leaf.

#### Information: Split level designs

The requirements of 3.1 do not prevent the use of split levels within the dwelling, including on the ground or entrance level. However, where a split level is used in the path of travel to one or more of the doors listed in the Application, those doors will still need to comply with 3.1.

### 3.2 Threshold

The threshold of an internal doorway that is subject to Clause 3.1 must—

- (a) be level; or
- (b) have a height not more than 5 mm if the lip is rounded or bevelled; or
- (c) have a ramped threshold that—
  - (i) does not extend beyond the depth of the door jamb; and
  - (ii) has a gradient not steeper than 1:8; and
  - (iii) is at least as wide as the minimum clear opening width of the doorway it serves.

### 3.3 Corridor width

Internal corridors, hallways, passageways or the like, if connected to a door that is subject to [Clause 3.1](#), must have a minimum clear width of 1000 mm, measured between the finished surfaces of opposing walls.

#### Applications

Clause 3.3 does not apply to a stairway that is in the path of travel to a shower complying with [Parts 5](#) and [6](#) that is on a level other than the ground or entry level.

#### Information

Skirting boards, architraves, timber mouldings, skirting tiles, door stops, conduits, general power outlets and the like may be disregarded for the purposes of compliance with [Clause 3.3](#).

Door hardware may encroach the required minimum corridor width.

## Part 4 Sanitary compartment

### 4.1 Location

There must be at least one *sanitary compartment* located on the ground or entry level of a dwelling.

#### Information

The term *sanitary compartment* refers to a room or space containing a toilet. It applies equally to any type of room or space containing a toilet, such as a bathroom, ensuite, powder room or other separate room. It is used in place of the word 'toilet' for consistency with the wording of the NCC and to avoid confusion with the use of the word 'toilet' to refer to a plumbing fixture rather than the room in which that fixture is located.

"At least one *sanitary compartment*" means that in a dwelling with two or more *sanitary compartments*, only one needs to be located on the ground or entry level and comply with the requirements of this Part.

### 4.2 Circulation space

A *sanitary compartment* that is subject to [Clause 4.1](#) must be constructed in accordance with the following:

- (a) For a toilet pan located in a separate *sanitary compartment*, there must be a clear width of not less than 900 mm between the finished surfaces of opposing walls either side of the toilet pan; or
- (b) For a toilet pan located in a *sanitary compartment* that is combined with a bathroom, the toilet pan must be located at least 450 mm from any other fixed obstruction, such as a basin or a vanity unit.
- (c) A clear minimum circulation space of 1200 mm by 900 mm must be provided from the front edge of the toilet pan.
- (d) Compliance with (c) must be determined in accordance with [Figure 4.2](#).

#### Applications

4.2(c) requires that a minimum circulation space of 1200 mm long by 900 mm wide clear space be provided in front of the toilet pan, and this applies for both a separate *sanitary compartment* and for a *sanitary compartment* that is combined with a bathroom. The minimum circulation space must be clear of the door swing and applies regardless of whether the door is inwards or outwards swinging or is a cavity slider.

Figure 4.2: Circulation space for a toilet pan

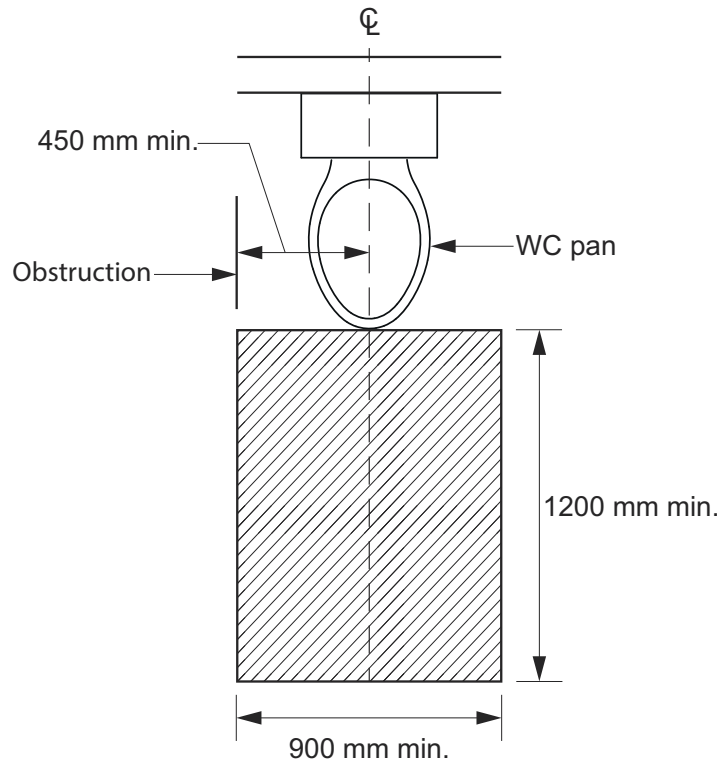

#### Information

- (1) NCC Volumes One and Two also contain requirements for the location and construction of *sanitary compartments*.
- (2) NCC Volume Three contains requirements for *plumbing* and *drainage* installations in *sanitary compartments*.
- (3) Skirting boards, architraves, toilet roll holders, skirting tiles, door stops and the like may be disregarded when determining compliance with Clause 4.2.

## Part 5 Shower

### 5.1 Application

At least one shower must comply with Clause 5.2.

#### Information

“At least one shower” means that in a dwelling with two or more showers, only one of the showers needs to comply with the requirements of this Part.

A shower subject to this Part is not required to be located on the ground or entry level of the dwelling.

### 5.2 Hobless and step-free entry

- (1) At least one shower must have a hobless and step-free entry.
- (2) A lip not more than 5 mm in height may be provided for water retention purposes.

#### Applications

For the purposes of 5.2, a lip meeting the requirements of 5.2(b) is not a step.

#### Information: Hobless and step-free

Clause 5.2(1) refers to a shower entry being ‘hobless’ and ‘step-free’ because those two terms have different meanings. A shower where the floor within the shower compartment is level with the floor adjacent to its entry would be ‘step-free’ but could still have a hob. Conversely, a shower with a step-down into the shower recess does not have a ‘hob’ (i.e. ‘hobless’), but would not be ‘step-free’. Therefore, to achieve the intent of Clause 5.2(1), it is necessary to specify that the shower is both ‘hobless’ and ‘step-free’.

#### Information: Waterproofing

AS 3740 and [Part 10.2](#) of the ABCB Housing Provisions include specific requirements for waterproofing a hobless, step-free shower area. Both are referenced in the NCC *Deemed-to-Satisfy Provisions* for general waterproofing of *wet areas* (note that [Part 10.2](#) of the ABCB Housing Provisions only applies to Class 1 and 10 buildings).

## Part 6 Reinforcement of bathroom and sanitary compartment walls

### 6.1 Location

- (1) Reinforcing in accordance with Clause 6.2 must be provided to any—
  - (a) *sanitary compartment* that is subject to Part 4; and
  - (b) bathroom containing a—
    - (i) shower that is subject to Part 5; or
    - (ii) bath (if provided), other than a freestanding bath where the bath is located in a room that also contains a shower that is subject to Part 5.
- (2) The requirements of (1) need not be complied with if the walls of the room are constructed of concrete, masonry or another material capable of supporting grabrails without additional reinforcement.
- (3) Where the wall supporting the reinforcement includes a cavity slider, it must be designed and constructed in way to support loads imposed by reinforcement, linings and the future provision of handrails and provided for the extent *required* by Figures 6.2a, 6.2b, 6.2c, 6.2d, 6.2e, 6.2f and 6.2g.

#### Information: Intent of Part 6

The intent of this Part is to ensure that walls adjacent to toilet pans, showers and baths provide a fixing surface able to support the future installation of grabrails, if needed. This Part does not require the installation of grabrails at the time of construction.

A freestanding bath is excluded from Clause 6.1(1)(b)(ii) because it does not have any adjoining walls to which grabrails could be fixed.

A bath with only one adjoining wall need only have reinforcing provided in the adjoining wall (unless exempted by Clause 6.1(2)). Care is required when locating a cavity sliding door adjacent to a fixture which requires reinforcement to 6.1(1) as the framing that surrounds the cavity into which the door retracts demands careful consideration of fixings and members that will safely support a grabrail and not impede the operation of the door.

#### Information: Non-combustibility of walls

Where noggings are *required* to achieve compliance with this Part, provided they do not extend further than necessary, these noggings may be installed within an *external wall* that is *required* to be *non-combustible* under C2D10(4)(i)(ii) of NCC Volume One.

### 6.2 Construction

- (1) Reinforcing constructed in accordance with the requirements of (3) must be provided in the locations depicted in—
  - (a) Figures 6.2a or 6.2b for walls surrounding a bath; and
  - (b) Figures 6.2c or 6.2d for shower walls; and
  - (c) Figure 6.2e for a wall adjacent to and within 460 mm of the centreline of a toilet pan; and
  - (d) Figures 6.2f or 6.2g for a wall behind a toilet pan where a wall described in (c) is not provided or a window sill or a door encroaches on the area *required* to be provided with reinforcing or where the toilet pan is not provided in a corner of the bathroom.
- (2) Reinforcing need only be provided across the available width of the wall where a wall referred to in (1)(a) or (b)—
  - (a) is narrower than the width of the area *required* to be provided with reinforcing; or
  - (b) terminates at a window sill lower than the height or the area required to be provided with reinforcing.
- (3) Reinforcing required by (1) must be constructed using one of the following materials:
  - (a) A minimum of 12 mm thick structural grade plywood, or similar.
  - (b) Timber noggings with a minimum thickness of 25 mm.



## Livable Housing Design

(c) Light gauge steel framing noggings or metal plate in accordance with the NASH Standard.

**Figure 6.2a:** Location of noggings for walls surrounding a bath

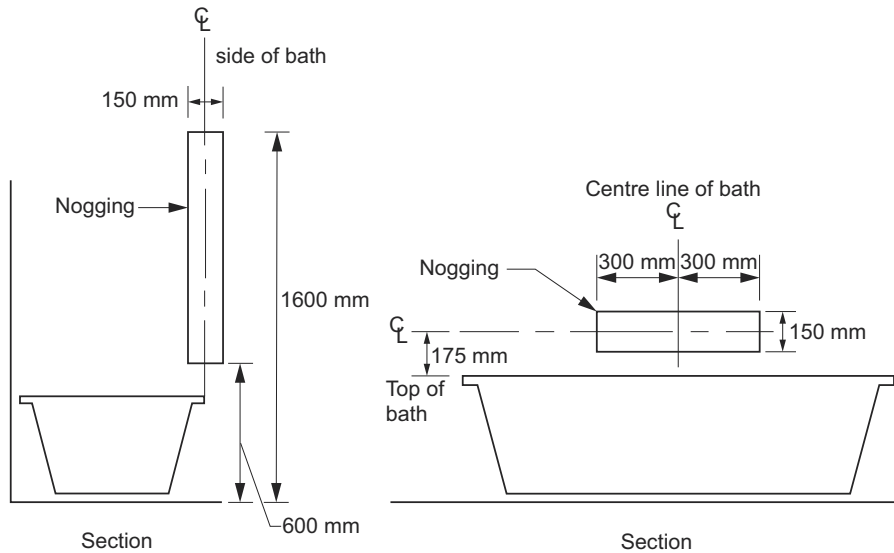

### Figure Notes

- (1) Taps, bath niches, soap holders and the like may be located within the positions designated for wall reinforcing.
- (2) Where the height of the bathtub is not yet known, an assumed height of 500 mm above finished floor level may be used to determine the location of wall reinforcing.

**Figure 6.2b:** Location of sheeting for walls surrounding a bath

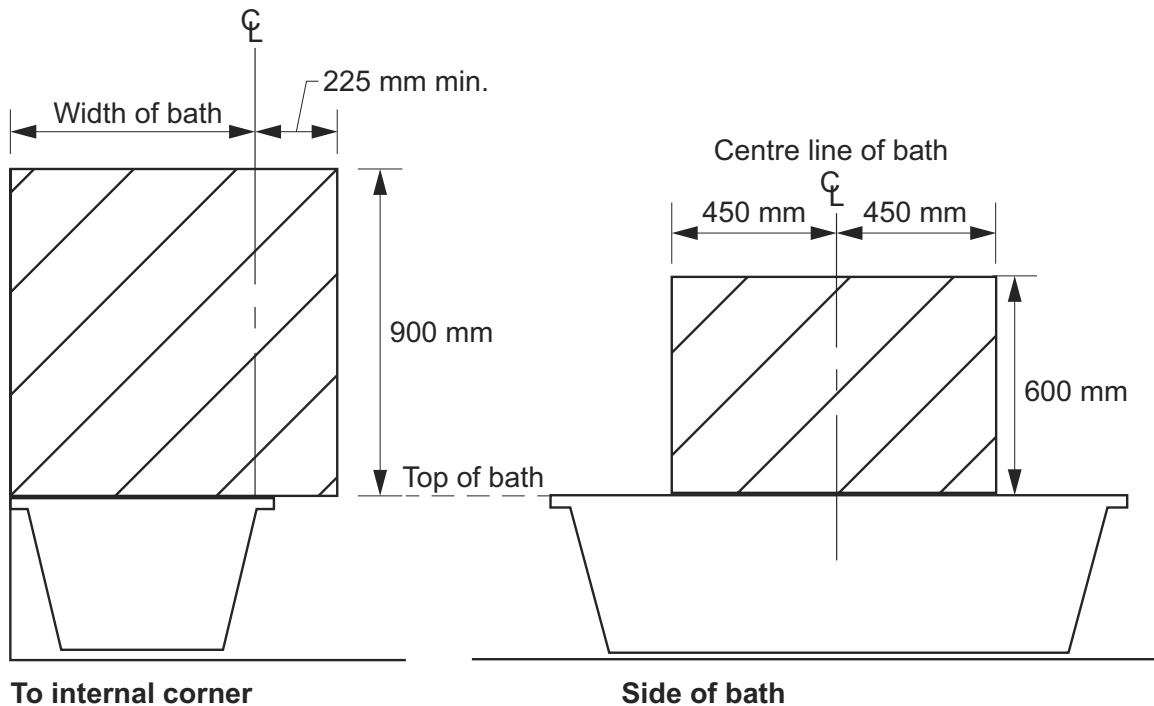

### Figure Notes

- (1) Taps, bath niches, soap holders and the like may be located within the positions designated for wall reinforcing.

Livable Housing Design

(2) Where the height of the bath tub is not yet known, an assumed height of 500 mm above finished floor level may be used to determine the location of wall reinforcing.

Figure 6.2c: Location of noggings for shower walls

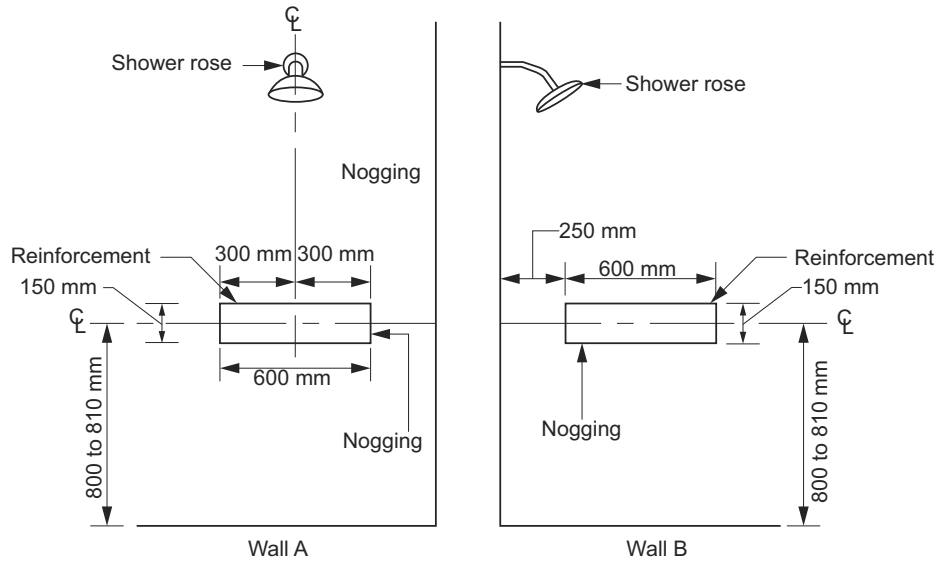

Figure Notes

Taps, bath niches, soap holders and the like may be located within the positions designated for wall reinforcing.

Figure 6.2d: Location of sheeting for shower walls

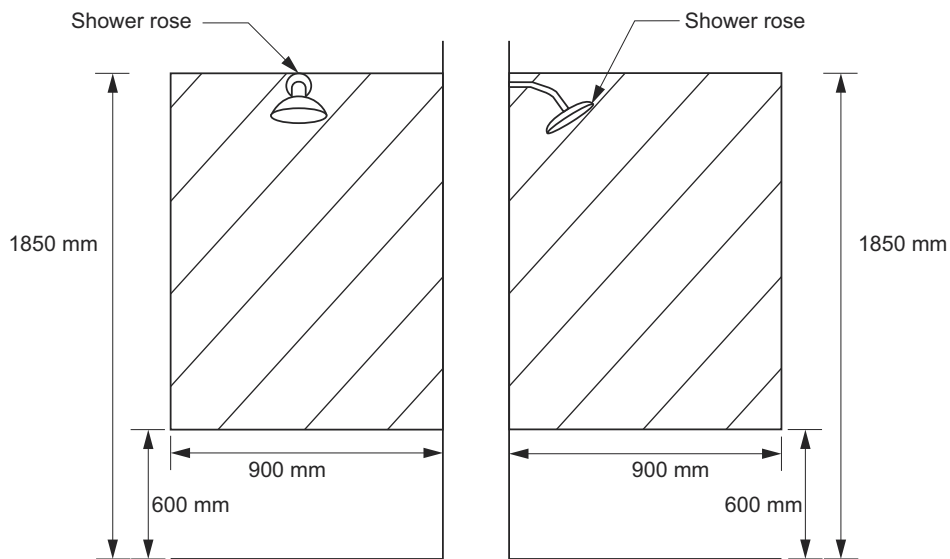
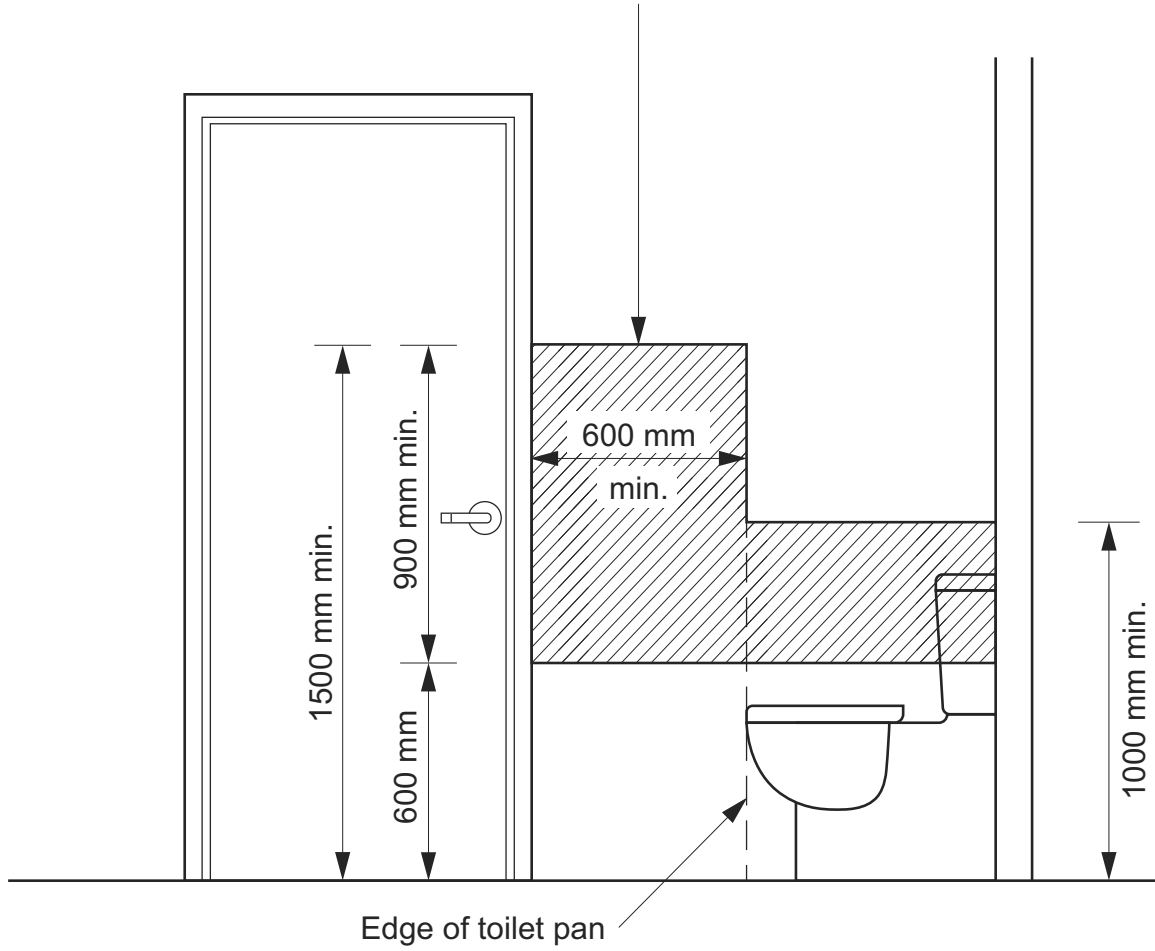

Figure Notes

Taps, bath niches, soap holders and the like may be located within the positions designated for wall reinforcing.

Livable Housing Design

Figure 6.2e: Minimum extent of sheeting for wall adjacent to a toilet pan  
Minimum extent of structural sheeting clear of any door frame, window frame or wall opening



Livable Housing Design

Figure 6.2f: Location of noggings for a wall behind a toilet pan

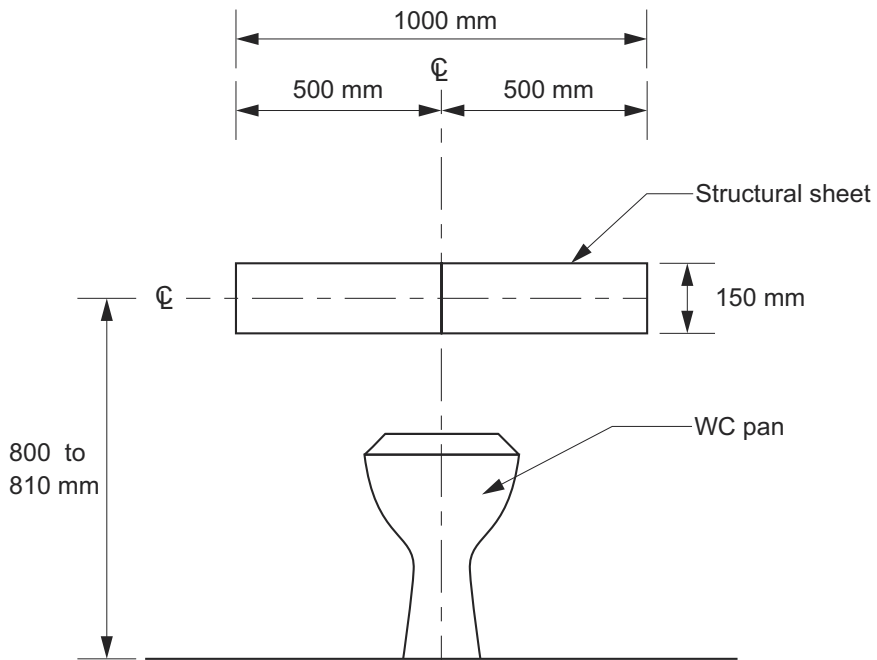
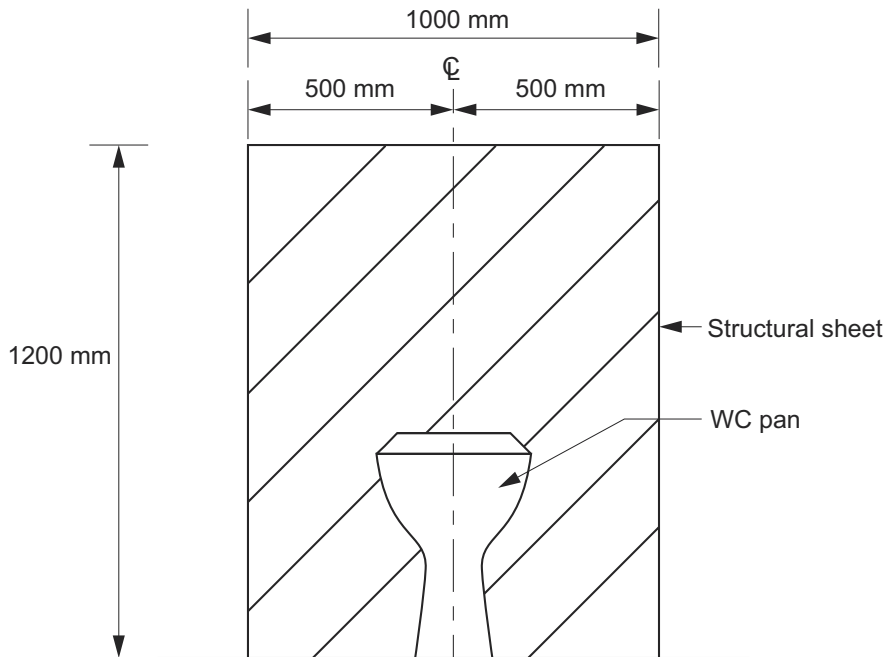

Figure 6.2g: Location of sheeting for a wall behind a toilet pan





© Australian Building Codes Board 2022  
The National Construction Code can be accessed  
free online at [ncc.abcb.gov.au](http://ncc.abcb.gov.au) by registration

**[abcb.gov.au](http://abcb.gov.au)**